

## Standard Products

# VRG8684

## Voltage Regulator, 3.0 Amp, Positive Low Dropout (LDO), Adjustable Radiation Tolerant

[www.aeroflex.com/voltreg](http://www.aeroflex.com/voltreg)

October 24, 2011



**AEROFLEX**  
A passion for performance.

### FEATURES

- ❑ Manufactured using  Linear Technology Corporation® Space Qualified RH1084 die
- ❑ Radiation performance
  - Total dose: 100 krad(Si), Dose rate = 50 - 300 rad(Si)/s
- ❑ Thermal shutdown
- ❑ Output voltage adjustable: 1.25V to 23V
- ❑ Dropout voltage: 1.80V at 3.0Amps
- ❑ 3-Terminal
- ❑ Output current: 3.0Amps
- ❑ Voltage reference: 1.25V +2%, -3.2%
- ❑ Load regulation: 0.35% max
- ❑ Line regulation: 0.25% max
- ❑ Ripple rejection: >60dB
- ❑ Packaging – Hermetic Ceramic
  - SMD-0.5 Surface mount
  - 3 Pads, .400"L x .296"W x .120"Ht
  - Power package
  - Weight - 2 gm max
- ❑ Designed for aerospace and high reliability space applications
  
- ❑ **Aeroflex Plainview's Radiation Hardness Assurance Plan is DLA Certified to MIL-PRF-38534, Appendix G.**

### DESCRIPTION

The Aeroflex Plainview VRG8684 consists of a Positive Adjustable (RH1084) LDO voltage regulator capable of supplying 3.0Amps over the output voltage range as defined under recommended operating conditions. The VRG8684 offers excellent line and load regulation specifications and ripple rejection.

Dropout ( $V_{IN} - V_{OUT}$ ) decreases at lower load currents.

The VRG8684 serves a wide variety of applications including SCSI-2 Active Terminator, High Efficiency Linear Regulators, Post Regulators for Switching Supplies, Constant Current Regulators, Battery Chargers and Microprocessor Supply.

The VRG8684 has been specifically designed to meet exposure to radiation environments and is configured for a SMD-0.5 SMT power package. It is guaranteed operational from  $-55^{\circ}\text{C}$  to  $+125^{\circ}\text{C}$ . Available screened in accordance with MIL-PRF-38534, the VRG8684 is ideal for demanding military and space applications.

For detailed performance characteristic curves, applications information and typical applications see the latest  Linear Technology Corporation® data sheets for their RH/LT1084, which is available on-line at [www.linear.com](http://www.linear.com).

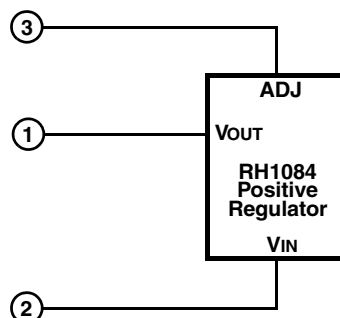

## ABSOLUTE MAXIMUM RATINGS

PARAMETER	RANGE	UNITS
Input Voltage	+25	VDC
Lead temperature (soldering 10 Sec)	300	°C
Input Output Differential	25	VDC
Load Current, maximum	6.0	A
Output Voltage	+25	VDC
ESD (MIL-STD-883, M3015, Class 2)	2000 to 3999	V
Operating Junction Temperature Range	-55 to +150	°C
Storage Temperature Range	-65 to +150	°C
Thermal Resistance (Junction to Case) $\Theta_{JC}$	2	°C/W

NOTICE: Stresses above those listed under "Absolute Maximums Rating" may cause permanent damage to the device. These are stress rating only; functional operation beyond the "Operation Conditions" is not recommended and extended exposure beyond the "Operation Conditions" may effect device reliability.

## RECOMMENDED OPERATING CONDITIONS

PARAMETER	RANGE	UNITS
Output Voltage Range	1.25 to 23	VDC
Input Output Differential	1.8 to 24	VDC
Case Operating Temperature Range	-55 to +125	°C

## ELECTRICAL PERFORMANCE CHARACTERISTICS 1/

UNLESS OTHERWISE SPECIFIED:  $-55^{\circ}\text{C} \leq T_C \leq +125^{\circ}\text{C}$

PARAMETER	SYM	CONDITIONS (P ≤ P <sub>MAX</sub> )	MIN	MAX	UNITS
Reference Voltage <u>3/</u> , <u>2/</u>	V <sub>REF</sub>	$1.5\text{V} \leq (V_{IN} - V_{OUT}) \leq 15\text{V}$ , $10\text{mA} \leq I_{OUT} \leq 3.0\text{A}$	1.210	1.275	V
Dropout Voltage <u>4/</u> , <u>2/</u>	V <sub>DROP</sub>	$\Delta V_{REF} = 1\%$ , $I_{OUT} = 3.0\text{A}$	-	1.8	V
Line Regulation <u>3/</u> , <u>2/</u>	$\frac{\Delta V_{OUT}}{\Delta V_{IN}}$	$I_{LOAD} = 10\text{mA}$ , $1.5\text{V} \leq (V_{IN} - V_{OUT}) \leq 15\text{V}$	-	0.25	%
Load Regulation <u>3/</u> , <u>2/</u>	$\frac{\Delta V_{OUT}}{\Delta I_{OUT}}$	$10\text{mA} \leq I_{OUT} \leq 3.0\text{A}$ , $(V_{IN} - V_{OUT}) = 3\text{V}$	-	0.35	%
Adjust Pin Current <u>2/</u>			-	120	μA
Adjust Pin Current Change <u>2/</u>		$10\text{mA} \leq I_{OUT} \leq 3.0\text{A}$ , $1.5\text{V} \leq (V_{IN} - V_{OUT}) \leq 15\text{V}$	-	5	μA
Minimum Load Current <u>5/</u> , <u>2/</u>	I <sub>MIN</sub>	$(V_{IN} - V_{OUT}) = 25\text{V}$	-	10	mA
Current Limit <u>2/</u>	I <sub>CL</sub>	$(V_{IN} - V_{OUT}) = 5\text{V}$	5.25		A
Ripple Rejection <u>3/</u>		$I_{OUT} = 3.0\text{A}$ , $(V_{IN} - V_{OUT}) = 3\text{V}$ , $f = 120\text{Hz}$ , $C_{ADJ} = C_{OUT} = 25\mu\text{F}$	60	-	dB
Thermal Regulation		30ms pulse, $T_C = +25^{\circ}\text{C}$	-	0.015	%/W
V <sub>REF</sub> Long-Term Stability <u>5/</u>		Burn In: $T_C = +125^{\circ}\text{C}$ @ 1000hrs minimum, Tested at $+25^{\circ}\text{C}$ .	-	1.0	%

Notes:

1/ The manufacturer's output current rating for the RH1084MK positive regulator integrated circuit is 5.0 Amps. For Compliance with the Current Density specification of MIL-STD-883 Rev. C, the electrical performance characteristics are specified at an output current of 3.0 Amps.

2/ Specification derated to reflect total dose exposure to 100krads (Si) at  $+25^{\circ}\text{C}$ .

3/ Line and load regulation are guaranteed up to the maximum power dissipation of 15W. Power dissipation is determined by the input/output differential voltage and the output current. Guaranteed maximum power dissipation will not be available over the full input/output voltage range.

4/ Dropout voltage is specified over the full output current range of the device.

5/ Not tested. Shall be guaranteed by design, characterization, or correlation to other tested parameters.

## VRG8684

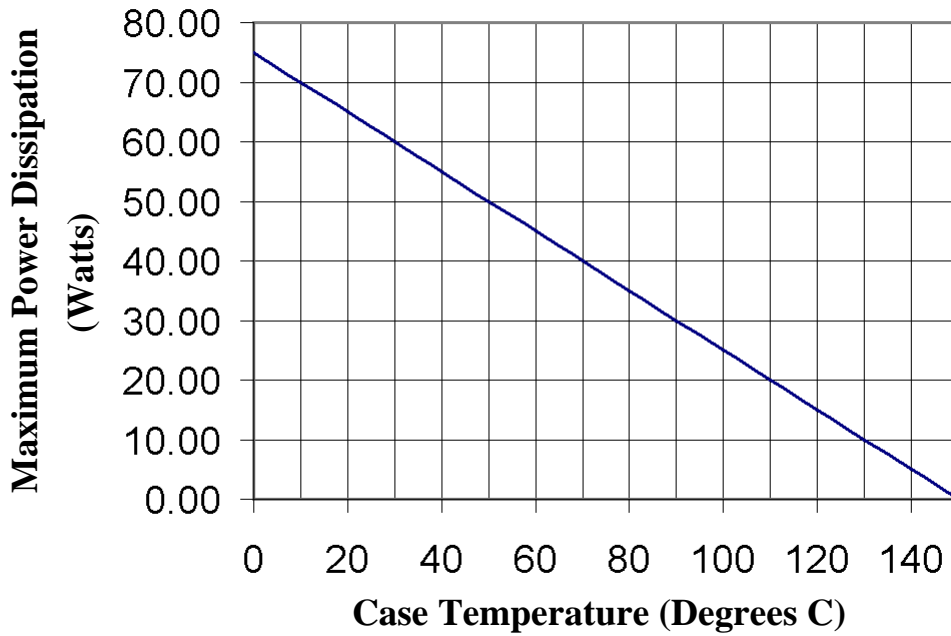

**FIGURE 2 – MAXIMUM POWER vs CASE TEMPERATURE**

The maximum Power dissipation is limited by the thermal shutdown function of the regulator chip in the VRG8684. The graph above represents the achievable power before the chip shuts down. The line in the graph represents the maximum power dissipation of the VRG8684. This graph is based on the maximum junction temperature of 150°C and a thermal resistance ( $\Theta_{JC}$ ) of 2°C/W.

## RH1084

See Note 1/ on page 2

### Typical Dropout Voltage

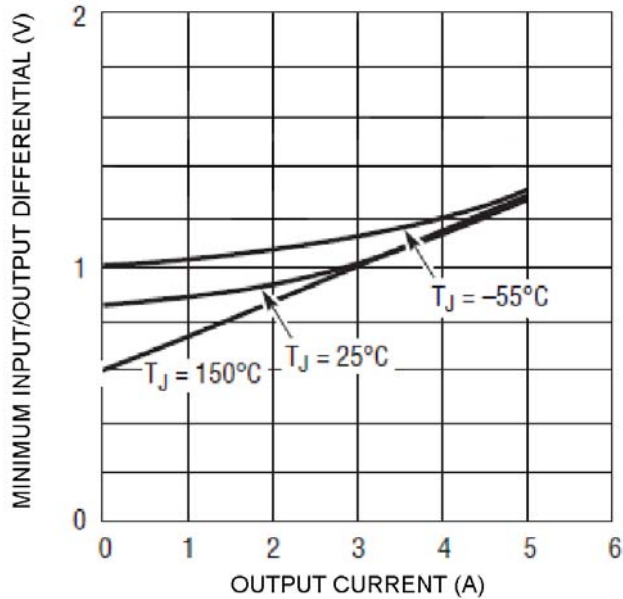

**FIGURE 3 – RH1084 DROPOUT VOLTAGE CURVE**

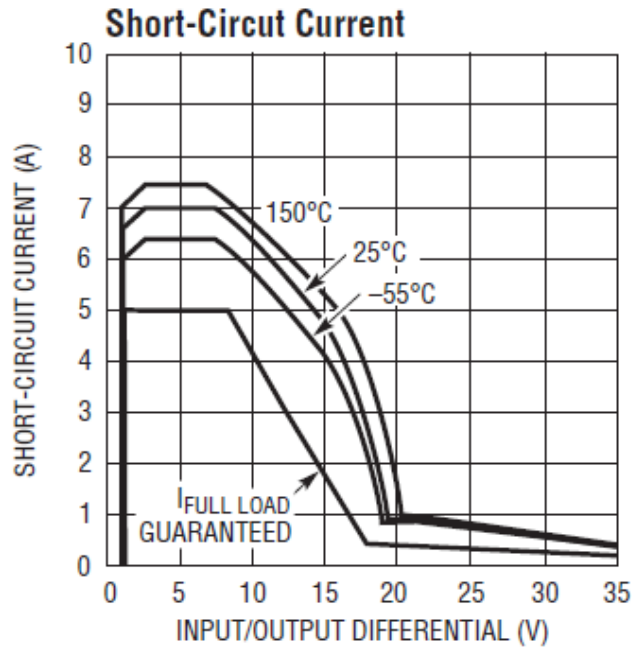

**FIGURE 4 – RH1084 SHORT CIRCUIT CURRENT**

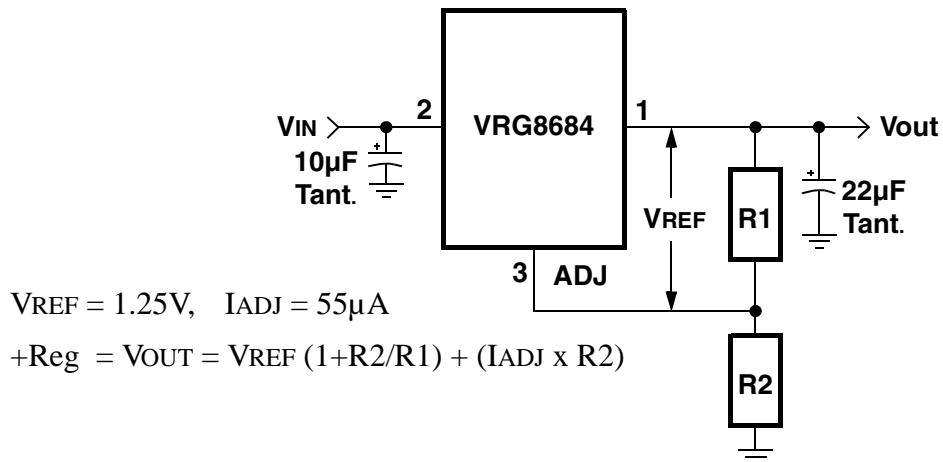

**FIGURE 5 – BASIC RH1084 ADJUSTABLE REGULATOR APPLICATION**

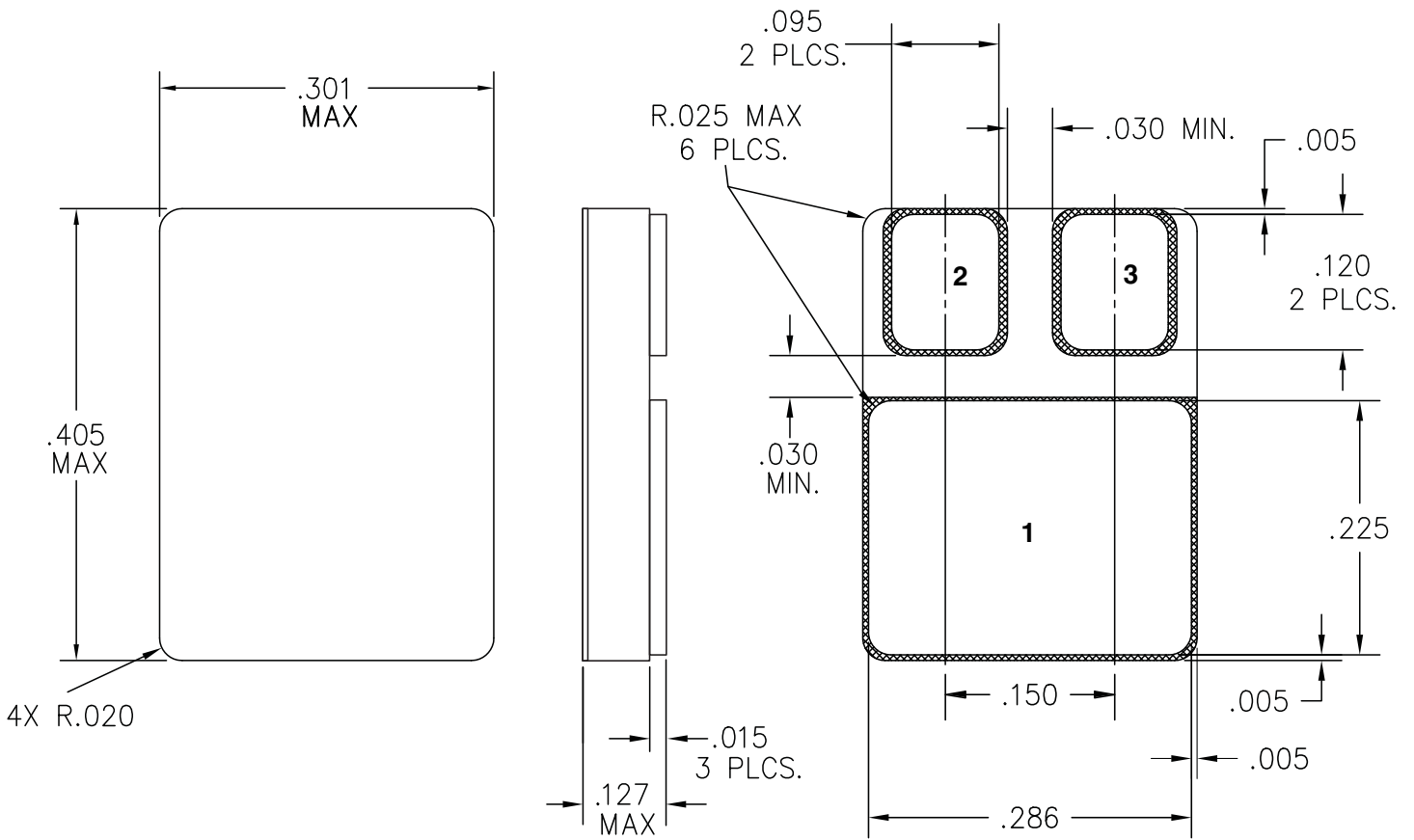

NOTE: Package & Lid are electrically isolated from signal pads.

**FIGURE 6 – VRG8684 PACKAGE OUTLINE — SURFACE MOUNT**

## ORDERING INFORMATION

MODEL	DLA SMD #	SCREENING	PACKAGE
VRG8684-7	-	Commercial Flow, +25°C testing only	SMD-0.5 Power Pkg
VRG8684-S	-	Military Temperature, -55°C to +125°C Screened in accordance with the individual Test Methods of MIL-STD-883 for Space Applications	
VRG8684-201-1S	5962-0924501KXC	DLA SMD Pending	
VRG8684-201-2S	5962-0924501KXA		

**EXPORT CONTROL:**

*This product is controlled for export under the International Traffic in Arms Regulations (ITAR). A license from the U.S. Department of State is required prior to the export of this product from the United States.*

**EXPORT WARNING:**

*Aeroflex's military and space products are controlled for export under the International Traffic in Arms Regulations (ITAR) and may not be sold or proposed or offered for sale to certain countries. (See ITAR 126.1 for complete information.)*

**PLAINVIEW, NEW YORK**

Toll Free: 800-THE-1553  
Fax: 516-694-6715

**INTERNATIONAL**

Tel: 805-778-9229  
Fax: 805-778-1980

**NORTHEAST**

Tel: 603-888-3975  
Fax: 603-888-4585

**SE AND MID-ATLANTIC**

Tel: 321-951-4164  
Fax: 321-951-4254

**WEST COAST**

Tel: 949-362-2260  
Fax: 949-362-2266

**CENTRAL**

Tel: 719-594-8017  
Fax: 719-594-8468



[www.aeroflex.com](http://www.aeroflex.com)    [info-ams@aeroflex.com](mailto:info-ams@aeroflex.com)

Aeroflex Microelectronic Solutions reserves the right to change at any time without notice the specifications, design, function, or form of its products described herein. All parameters must be validated for each customer's application by engineering. No liability is assumed as a result of use of this product. No patent licenses are implied.



and the Linear Technology logo are registered trademarks and RH1084 are a copyright of Linear Technology Corporation.



Our passion for performance is defined by three attributes represented by these three icons: solution-minded, performance-driven and customer-focused